

TEST BENCH SERIES

FMTB

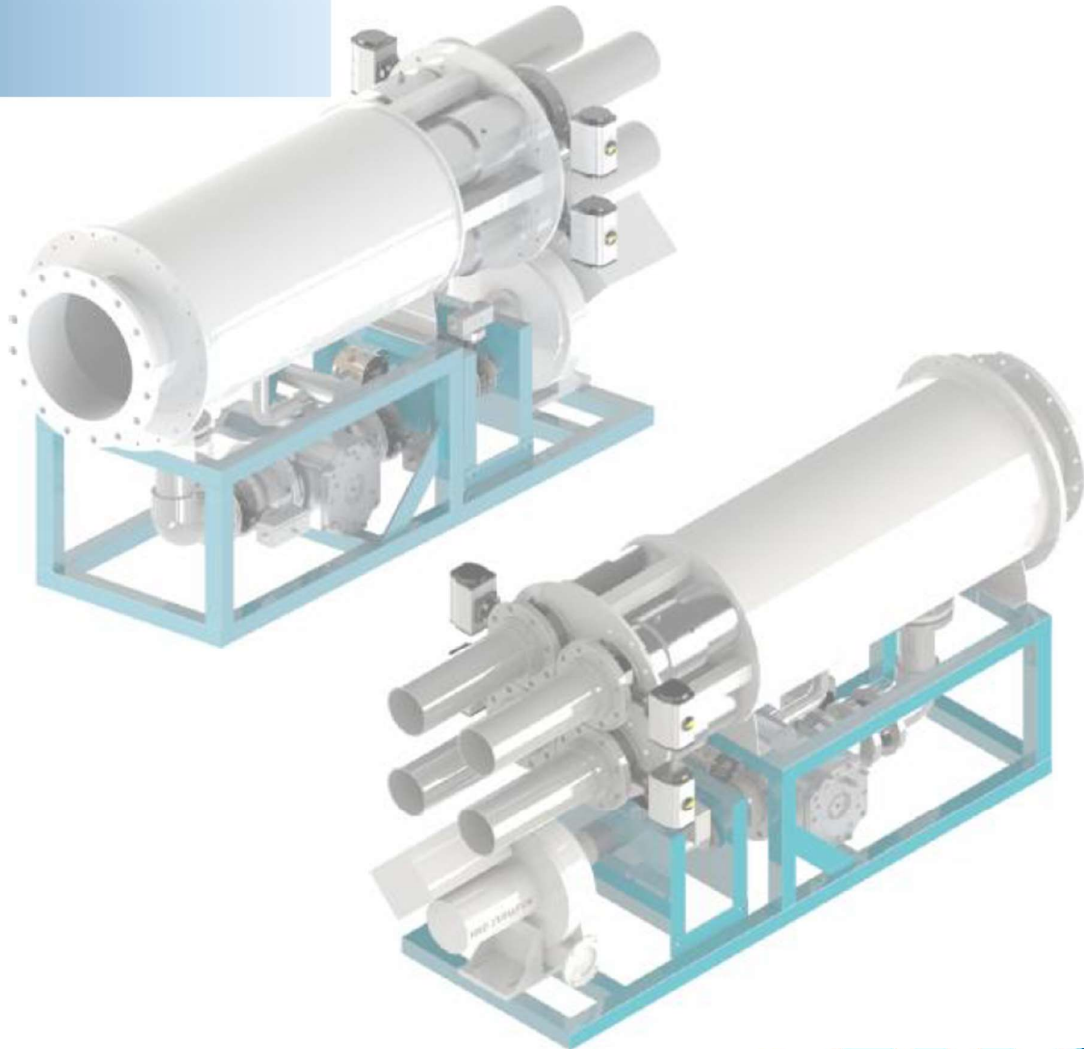

Model FMTB-5000B/IO

Technical Specification

Technical Specification

This specification contains the description and bill of materials of a FMTB-5000B/IO test bench suitable for testing, calibration and verification of various flow meters like diaphragm, rotary and turbine meters, under atmospheric air conditions.

It is recommended to clean the meters under test before testing or install additional filters to protect the master meters.



Item Description

Modular Test Bench, assembled, tested and wired ready for installation / hook-up on site to locally made interconnecting pipe work, consisting of the following:

01 Master Meter Section

- One header/silencer/flow conditioner to connect the meter under test with the two master meter runs. The inlet header has a 16" DIN/ANSI150 front connection to the Meter Under Test (MUT).

- One master meter line consisting of:
 - Rotary meter, type FMR-M16 Dual Type 18 - 560cfh (0,5 - 16 m3/h) equipped with HF, calibrated by FMG with traceability to VSL (Dutch Metrological Institute)
 - Electrically operated block valves
 - Class A temperature sensor 4 wire PT100, accuracy better than 0.18F (0,15°C), range 50 – 104F (10 – 40°C),
 - Pressure connection (Pr-point master meter)
 - Filter / Sieve

- One master meter lines consisting of:
 - Rotary meter, type FMR-M650 Dual Type, capacity 560-23,000cfh (10 - 650 m3/h) equipped with double HF, calibrated by FMG with traceability to NMi
 - Class A temperature sensor 4 wire PT100, accuracy better than 0.18F (0,15°C), range 150 - 104F (0 – 40°C)
 - Pressure connection (Pr-point master meter)
 - Filter / Sieve

- Two master meter lines consisting of:
 - Turbine meter, type FMT-M2500, capacity 18,000–88,000cfh (500 -2500 m3/h) equipped with double HF, calibrated by FMG with traceability to NMi.
 - Class A temperature sensor 4 wire PT100, accuracy better than 0.18F (0,15°C), range 150 - 104F (0 – 40°C)
 - Pressure connection (Pr-point master meter)
 - Filter / Sieve

- One set pressure (Pr, dP) tubing for Pr-points from Master Meters and Meter Under Test
- Two HF sensors and cabling per Master Meter

02 Uncertainty Levels (CMC according ILAC-P14:01/2013):

- 35 – 175,000cfh (1 – 5000 m³/h) < 0,25%
- 18 – 35cfh (0,5 – 1 m³/h) < 0,50%

03 Blowers and flow control

- One blower with capacity of >23,000cfh (650m³/h), approx. 2.2kW at 230VAC 50 - 60 Hz, type centrifugal (Elektror (Germany) or equivalent), including a frequency controller.
- Pneumatically operated 4" control valve 87psi (6 bar) max.
- Pneumatically operated 2" control valve 87psi (6 bar) max.
- Electrically operated 1" control valve

- Two blowers with capacity of >88,300cfh (2500 m³/h), approx. 7.5kW at 400 - 480 VAC 50 - 60 Hz, type centrifugal (Elektror (Germany) or equivalent), including a frequency controller.
- Block valve with pneumatic actuators for line switching 87psi (6 bar) max.

04 Electronic Cabinet

- Free standing, RAL 7035, rated power approx. 500Watt, 230 Vac.
- Side Panel with main on/off switch
- Power supply unit 230 VAC, 50 Hz / 24 VDC
- Module for Meter-Under-Test
- One set of interfaces to the Meter Under Test consisting of a wiring block to connect several pulse sources simultaneously
- Module for flow control
- Module for master meters
- Pr, dP sensors, repeatability better than 0.005 psi (0.32 mbar) (this includes linearity, hysteresis and repeatability)
- Absolute pressure sensors, accuracy better than 0.015 psi (1 mbar)

- Automatic leak control switches and valves
- Completely wired

05 PC Configuration and software

- NUC or similar with Intel Core i series
- RAM: minimum 4GB DDR3-1600
- Solid State Drive: minimum 60 GB
- Screen: 22" LCD High Resolution
- Keyboard (English Version), mouse
- One Ethernet Port 1Gbps
- Windows 10 or higher (English Version)

06 Test Bench Control Software

- User friendly interface
- Various levels of access from basic operators to advanced users and settings
- Advanced test method using high speed simultaneous data collection from all sensors
- Fast testing cycles for meters being fitted with HF sensors
- Test results are shown on screen and automatically saved
- Printed reports are available with configurable report layout

07 Remote Control Software

- Pre-installed version of remote access software (e.g. TeamViewer)
- Allows for remote connection and support by FMG

08 Meter Under Test Interface

- Meter Under Test Interface box is front panel mounted to connect several pulse sources simultaneously
- One set of interfaces consisting of four sensor inputs, each capable of handling HF Pulse, LF Pulse or Optical Index Detection

09 Documentation

- Schematic diagrams
- Hardware manual
- Software manual
- Certificates

10 Required connections on site (not included in this delivery):

- Electrical power for blowers / flow control
- Electrical power for control cabinet
- Compressed air supply minimum 90psi (approx. 6 bar) free of oil, filtered
- Lifting crane or lifting tables
- Internet connection for remote support
- Inlet and outlet piping for meter under test

11 Optional:

- In and outlet piping in compliance with international standards
- Automatic clamping device
- Transfer master meters set (traceable to VSL)
- Certification by VSL

Image 1: Main inlet DN400 (16") for turbine meters and ultrasonic meters



Image 2: DN150 (6") side inlet for testing rotary meters and turbine meters up to 500 m³/h



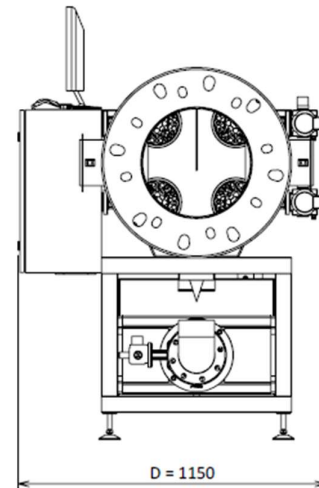
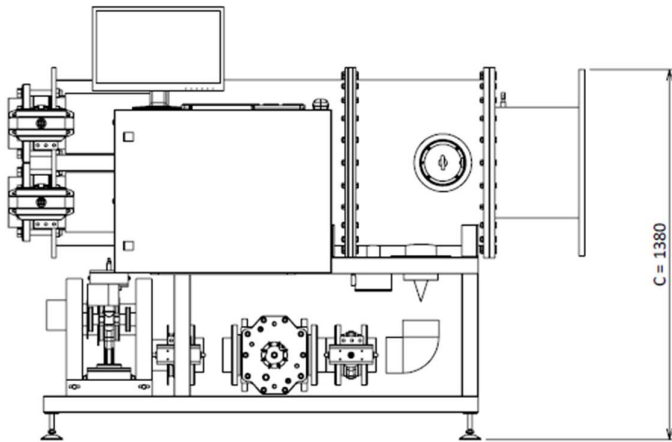
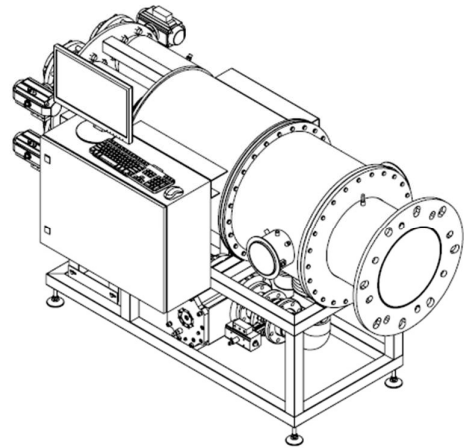
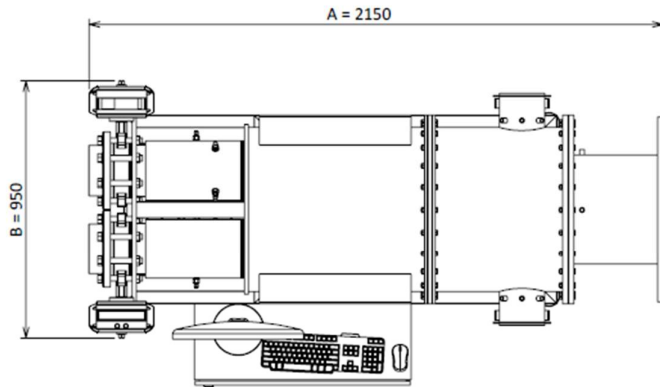

Imperial units	
A	7 ft
B	3.1 ft
C	4.5 ft
D	3.8 ft
Weight	2100 lb